

DOLPHIN

Mechanical Key Cutting Machine
XP-007

User Manual

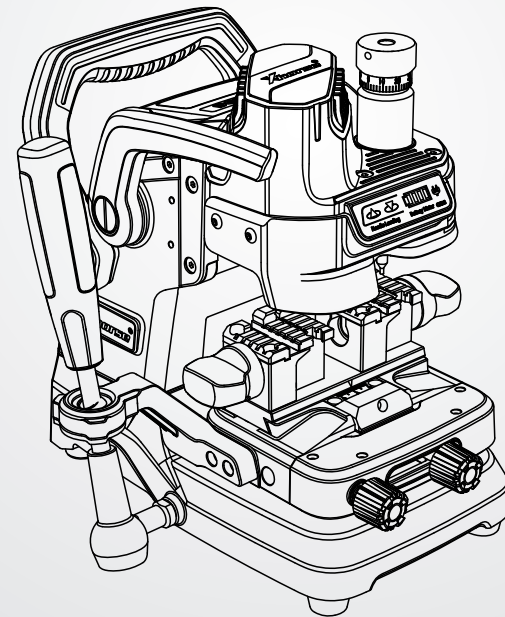



XP-007
Mechanical Key Cutting Machine

TABLE OF CONTENTS

1	Safety precautions and warnings	02
2	General information	
2.1	Machine description	03
2.2	Machine characteristics	03
3	Product packaging checklist	04
4	Overview	
4.1	Structure diagram	06
4.2	Specification	07
4.3	Main parts with function description	09
4.3.1	Auxiliary handle	09
4.3.2	Main handle	10
4.3.3	Switch	11
4.3.4	Indicative light for height leveling	11
4.3.5	Micro-adjuster	12
4.3.6	Locking knob	12
4.3.7	Supporting arm	13
5	Machine installation and setting	
5.1	Main handle installation	14
5.2	Probe and cutter installation and uninstallation	15
5.3	Clamp installation and uninstallation	17
5.4	Clamp position calibration	18
5.5	Probe/cutter height adjustment	20
5.6	Fuse replacement and installation	21
6	Operation guide	
6.1	Key alignment	22
6.2	Key installation guide	23
6.2.1	Sided keys installation	23
6.2.2	External keys and internal keys fixation	24
6.2.3	Arc-types keys fixation	25
6.2.4	Tubular keys fixation	26
7	Maintenance	27
8	Warranty and after-sale description	27

1. Safety precautions and warnings

To avoid injuries to operator or damages to machine, please read through this product user manual carefully before you start and follow the safety notes listed below:

- Always use the machine under safe environment
- Put the machine on a flat and firm platform
- Do not expose machine to the hot sun, or place the machine in a place that is damp, greasy and dusty
- Keep the machine dry and clean and do not put anything on the machine
- Place the machine in a place that is out of children's reach
- Wear protective goggles that are in line with ANSI standard
- Do not get too close to the machine when it is working
- Do not leave the machine unattended when it is working
- Do not use a damaged or loose socket and the power socket what use for charging must has ground cable
- Unplug the machine when it is not in use for a long time or it is under maintenance
- Unplug the machine instantly under unusual circumstance

2. General information

2.1 Machine description

Dear customers, thank you for choosing Dolphin XP-007 mechanical key cutting machine. Dolphin XP-007, with a small volume and light weight, is particularly and carefully designed for locksmiths worldwide. This product user manual provides operating instructions for you to use the machine correctly and safely. To avoid injuries and financial loss, please carefully read this manual through before you start to operate the machine. And we kindly remind you to keep this manual properly for future reference. The images and colors of the machine shown in this user manual are indicative only. If there is inconsistency between the images and actual products, the actual products prevail.









2.2 Machine characteristics







Dolphin XP-007 is a mechanical key cutting machine with the following characteristics:

- Ergonomic design, easy to carry
- Innovative design of multifunctional clamp
- Build-in Lithium battery with a long battery life
- Supporting sided/track/tubular keys
- Multi-switching high speed motor
- Micro-adjuster for dimple keys more accuracy with prepositioning function
- Smart adjustment display and battery level
- Aluminum structure
- Cross rail with high rigidity
- Highly sensitivity operating platform

3. Product packaging checklist

A full package of XP-007 should include accessories listed in the following table. Please have a thorough check when you get this product and contact your distributor if anything in the table is missing.

Name	Sample picture	Quantity	Description
Machine		1	Key cutting machine
Handle		1	Z axis working handle
2.5mm cutter		1	Cutting tool ($\varphi 2.5 * \varphi 6 * 40L$)
1.5mm cutter		1	Cutting tool ($\varphi 1.5 * \varphi 6 * 40L$)
Double-sided probe		1	Probing tool ($\varphi 1.5 * \varphi 2.5 * \varphi 6 * 45L$)
Align stopper		2	Key tip aligning tool
2mm hexagon bar wrench		1	Probes and cutters installation tool
4 mm hexagon bar wrench		1	Clamp installation tool
Power adapter		1	Power supply

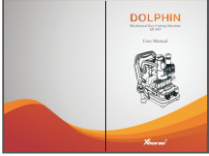
Shim		2	assisting fix the cutting of sided keys
1.5m Power cord of China standard		1	Connect to power
1.5m Power cord of UK standard		1	Connect to power
1.5m Power cord of US standard		1	Connect to power
1.5m Power cord of EU standard		1	Connect to power
Brush		1	Cleaning tool
Product quality certificate		1	Factory inspection report and packing list
User manual		1	Machine assembly/adjustment/operation instruction

*Notes:

- Replace cutters regularly to ensure the cutting efficiency.
- Please use a 10A fuse.

4. Overview

4.1 Structure diagram

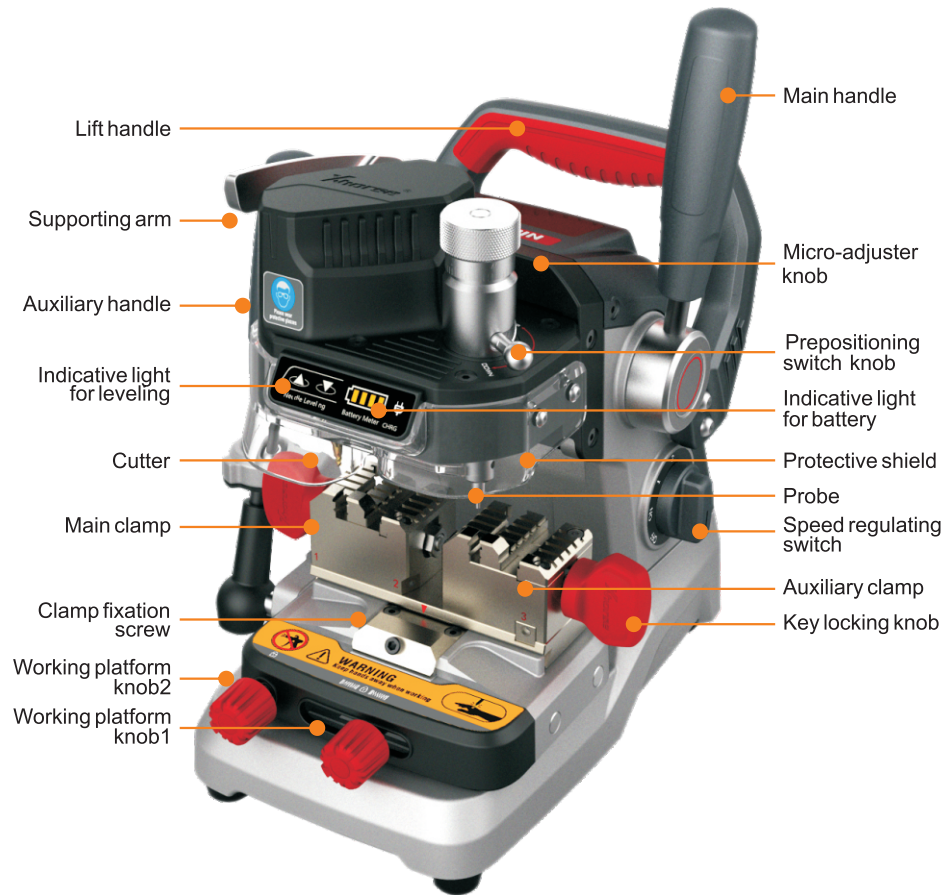

4.2 Specification

Input voltage	12-24V
Battery capacity	65.52Wh
Power	120W
Main axis rotation speed	Maximum : 13000RPM Gear1 : 8000RPM Gear2 : 10000RPM
Motor Torque	Gear1 : 0.12 N.M Gear2 : 0.16 N.M
Main axis displacement	25MM
Operating platform displacement	X axis : 36mm Y axis : 50mm
Working temperature	0-50°C
Working Humidity	10-90%
Machine dimension	270*168*355mm
Package dimension	380*340*360mm
Net weight	11.5kg
Gross weight	14kg



Machine size

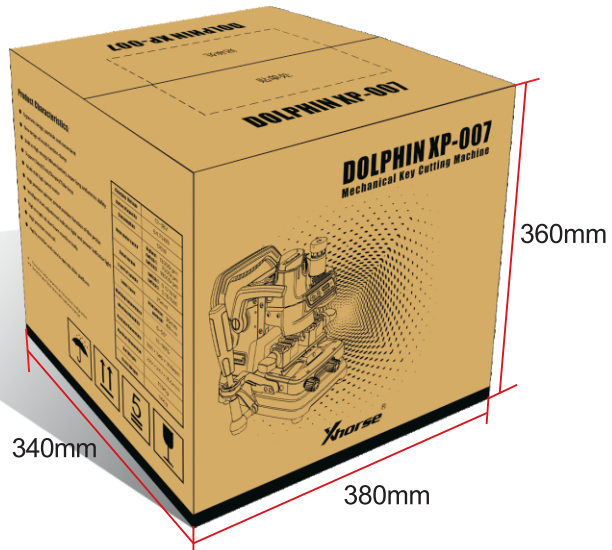

Package size

4.3 Main parts with function description

4.3.1 Auxiliary handle

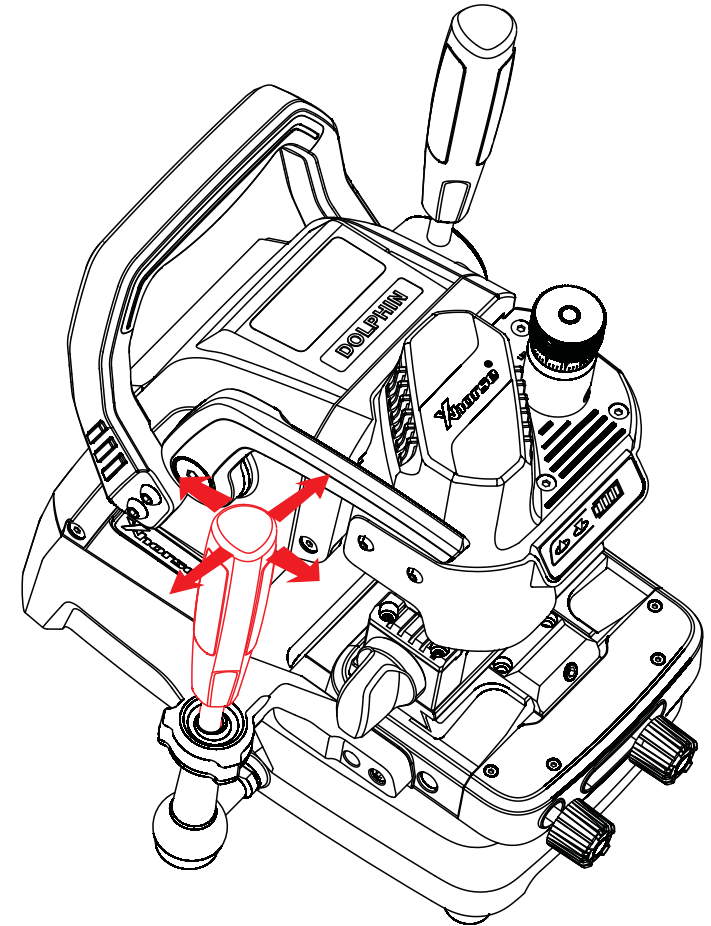

Auxiliary handle is to control the horizontal movement of the cutting platform.

4.3.2 Main handle

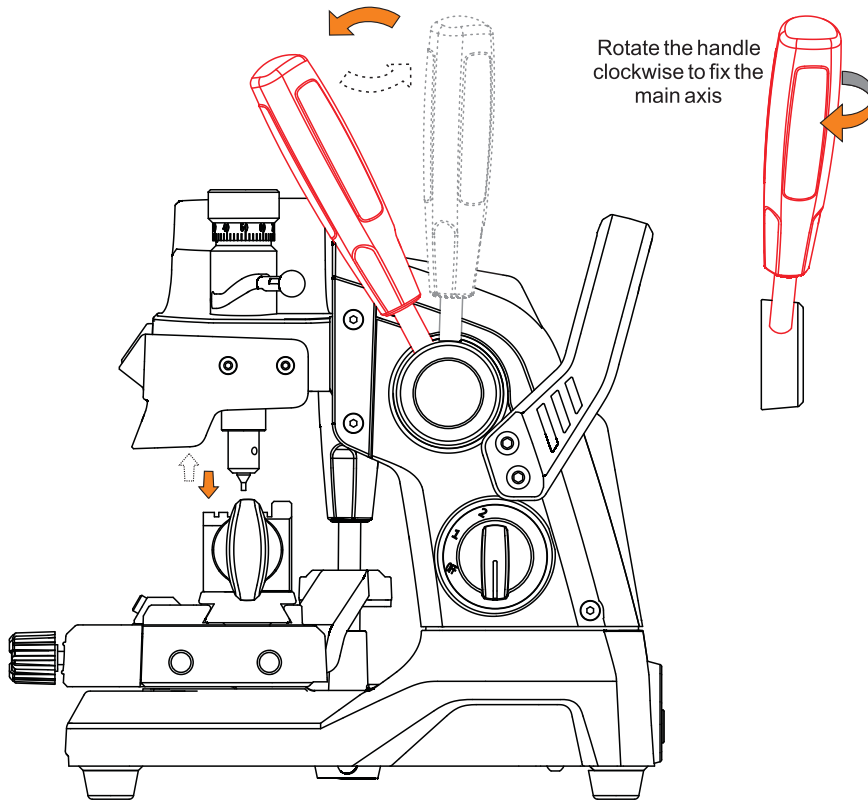

- 1) Move the handle forward or backward to adjust the height of the cutter and probe. The cutter and probe will go back to its initial height when dropping the handle.
- 2) Move the handle to set the height of the cutter and probe and lock them by rotating the handle clockwise.

4.3.3 Switch

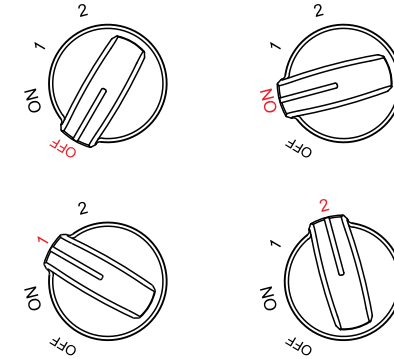

Power switch and speed selection, include OFF, ON, 1, 2 switch position.

- 1) Power is off when switching to 'OFF'.
- 2) Power is on when switching to 'ON', the LED light is on and the machine is on standby.
- 3) The motor is on low speed of 8000 rpm when switching to '1'.
- 4) The motor is on high speed of 10000 rpm when switching to '2'.

4.3.4 Indicative light for height leveling

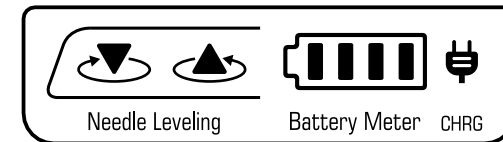

- 1) For adjusting height indicator light.
 Only leftside light on, probe height higher than cutter. Move the micro-adjuster knob clockwise to let probe move down.
 Only rightside light on, cutter height higher than probe. Move the micro-adjuster knob counter-clockwise to let probe move up.
 Only probe and cutter at same height, both light on.
- 2) Battery status
 Full lights on means battery full charge
 Only one green light on, means battery low, please recharge on time.
 Only one red light on, means battery badly low, please recharge asap
- 3) For charging setting
 Charging setting is red means battery low, need to recharge or charging
 Charging setting is green means battery full. You can unplug the power cord.

*Notes:

If the machine without Li-ion battery pack, plug in power cord, the battery indicator is green and the charging indicator lights up in green.

4.3.5 Micro-adjuster

Micro-adjuster includes micro-adjuster knob and prepositioning switch.

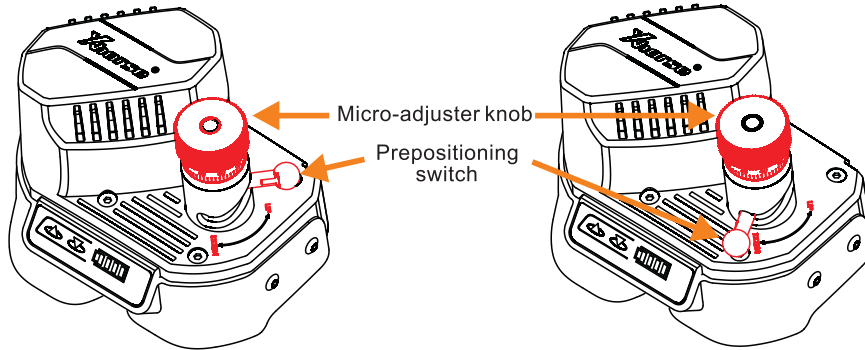

- 1) Micro-adjuster knob allows precise adjustment the height of probe, Turn the knob clockwise to move down the probe and counter-clockwise to move up the probe.
- 2) Prepositioning switch mainly support setting position in advance, mainly for cutting dimple keys more accuracy, When the prepositioning switch is at 'UP', setting position function disabled, prepositioning switch is at 'Down', setting position function enabled, the probe height is lower than the cutter because of inside spring but it can bounce back to a level same to the cutter, when cutting dimple keys, probe will be detected the original key centre point in advance, cutting keys with more accuracy.

4.3.6 Locking knob

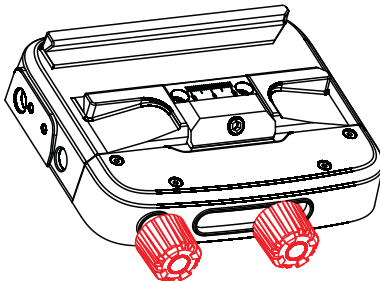

- 1) When the right locking knob is tightened, the working platform from is restricted to move in a smaller distance, it will be easy to control the cutting key width.
- 2) When both locking knobs are tightened, the working platform can only move along Y axis but not along X axis, when cutting dimple keys, in case of the platform horizontal shaking because of the cutting.

*Notes:

Probe micro-adjuster function for prepositioning function only switch at 'UP' position, or may affected on cutting accuracy.

4.3.7 Supporting arm

- 1) The supporting arm with damping effect, it can move up and down.
- 2) When the machine is in use, move the supporting arm to a proper position where you feel good.

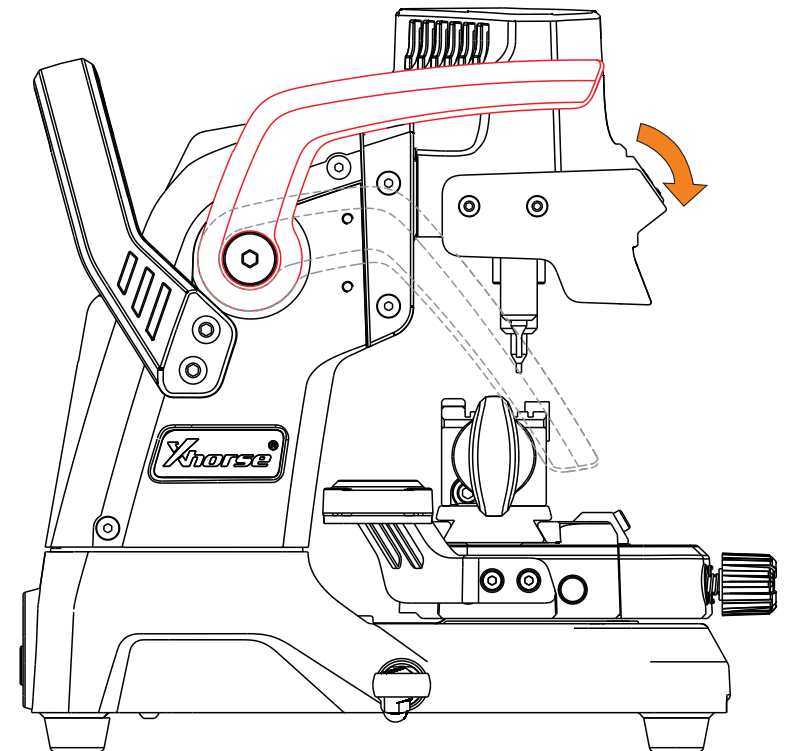

*Notes:

When moving the machine, the supporting arm can be moved forward limited to prevent clamp from shifting.

5. Machine installation and setting

5.1 Main handle installation

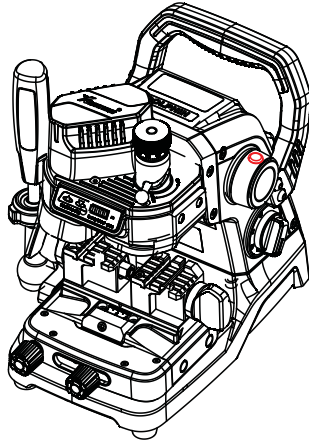

The machine is packaged without the main handle installed like picture above.

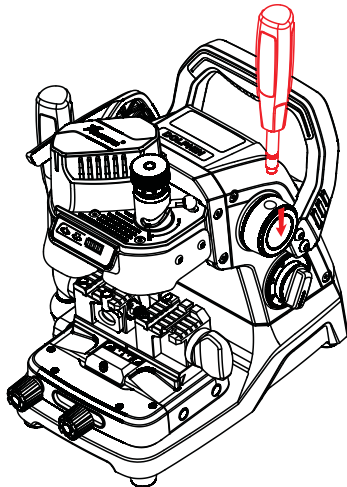

- 1) Take off the screw nut and screw in the handle till it is tight.
- 2) When the handle is very tight, the probe and cutter are fixed.
- 3) Rotating the handle counter-clockwise to 180 degrees and reach a half-tightened state, the vertical position of the probe and cutter can be adjusted randomly.

***Notes:**

Auxiliary handle hole built-in copper cylinder, for handle tighten special part. After remove the screw, do not turn over the machine, in case of copper cylinder comes out.

5.2 Probe and cutter installation and uninstallation

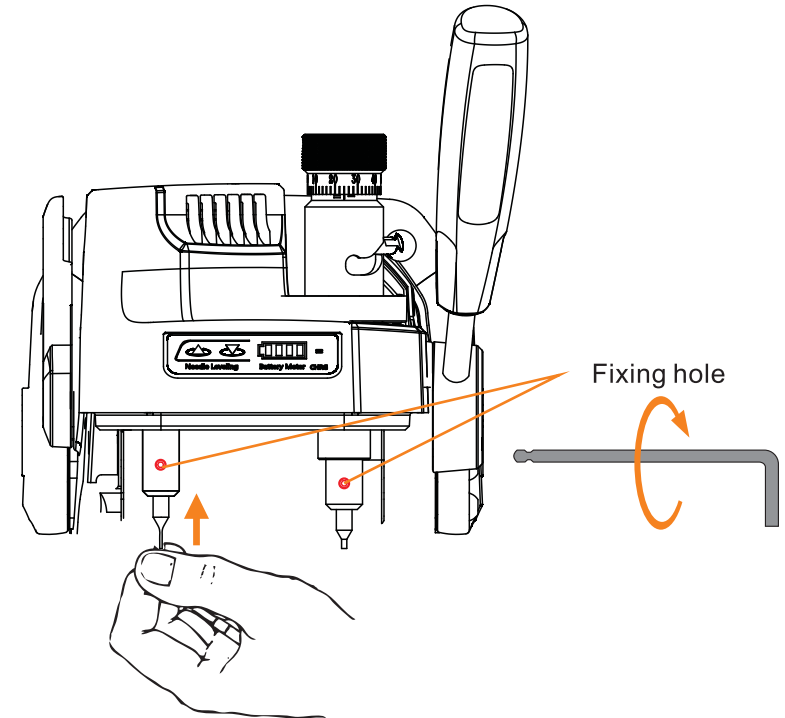

- 1) Cutter is on the left. Probe is on the right. With the slot facing the screw, place the probe/cutter in the mounting holes to the limit and fixing the cutter/probe with a hexagon bar wrench.

***Notes:**

- Make sure the machine is power off before changing the cutter/probe.
- When 1.5 mm and 2.5 mm cutters are used, the probe should be of the same diameter with the cutter.

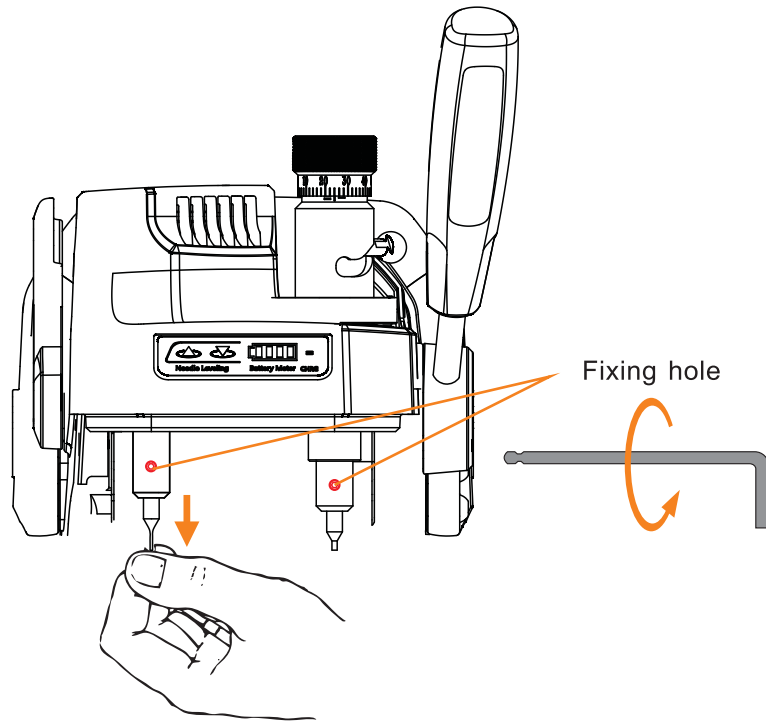

2) To uninstall the cutter/probe, unscrew them with the hexagon bar wrench by turning it counter-clockwise.

*Notes:

- Make sure the machine is power off before changing the cutter/probe.
- When 1.5 mm and 2.5 mm cutters are used, the probe should be of the same diameter with the cutter.

5.3 Clamp installation and uninstallation

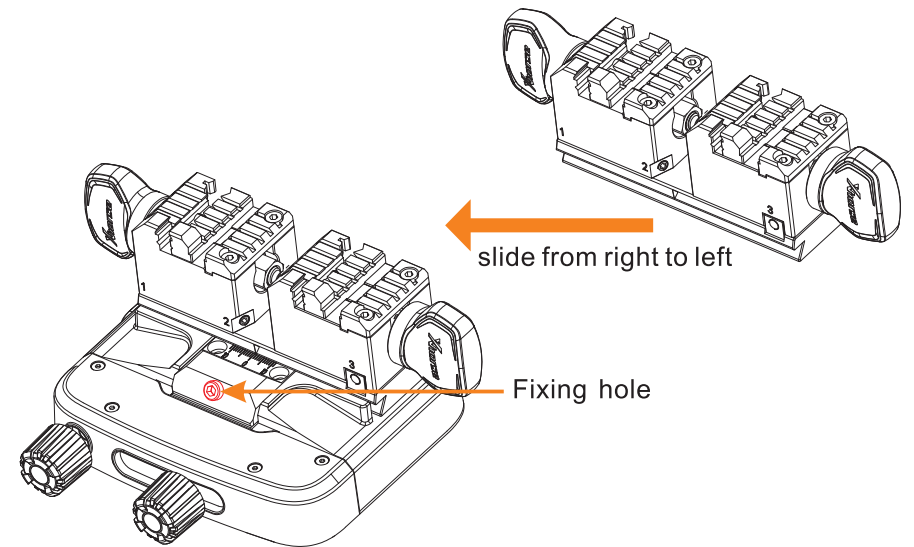

- 1) Clamp installation: Slide the clamp into the clamp slot from right side and fix it by tightening the screw. The clamp in the slot can be left or right shifted depending on the user's need. The clamp is in position of middle if the triangle of clamp align with arrow mark in the platform.
- 2) Clamp uninstallation: Loosen the screw and pull out the clamp from right side.
- 3) Clamp reversion: The clamp can be fix reversed, it is depend on what types of keys need to be cut.

5.4 Clamp position calibration

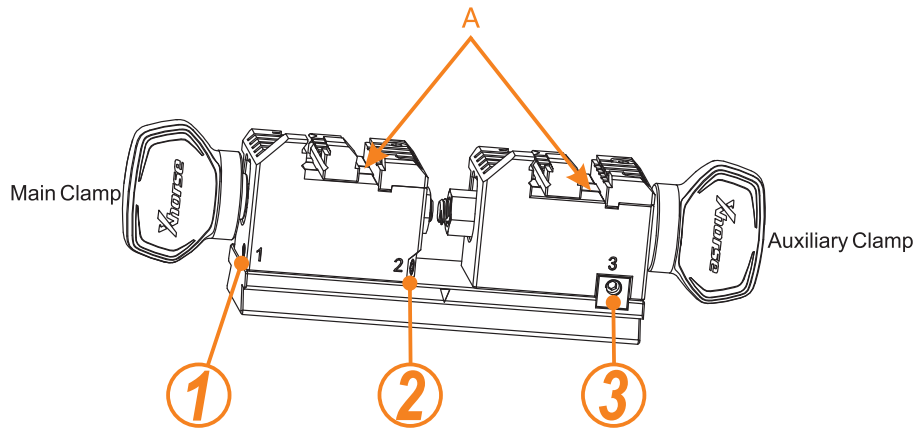

The clamp need to be calibrated for horizontal position after the clamp is installed, which including the horizontal X axis and Y axis, use two probes of same size or same diameter cutter and probe, Install those two probes to the position of cutter and probe then do the height level adjustment.

The X axis calibration procedures as follow:

- 1) Let two probes touch the surface A of main clamp and auxiliary clamp, if the two probes can't touch the surface A of main clamp and auxiliary clamp at the same time, need to adjust the distance of both clamp on X axis.
- 2) For increase(reduce) main and auxiliary clamp distance, use 2.5mm hexagon bar wrench to loose position 1(position 2) screw, then tighten position 2(position 1) screw, let main clamp move to left(right) side, until two probes touch the surface A at the same time, after that tighten position 1(position 2) screw, X axis calibration completely.

The Y axis calibration procedures as follow:

- 1) Let two probes touch the surface B of main clamp and auxiliary clamp , if the two probes can't touch the surface B of main clamp and auxiliary clamp at the same time, need to adjust the distance of both clamp on Y axis.
- 2) When the auxiliary clamp located at inside(outside) position, use 2.5mm hexagon bar wrench to loose position 3(position 4) screw, then tighten position 4(position 3) screw, let auxiliary clamp move to outside(inside) direction, until two probes touch the surface B at the same time, after that tighten position 3(position 4) screw, Y axis calibration completely.

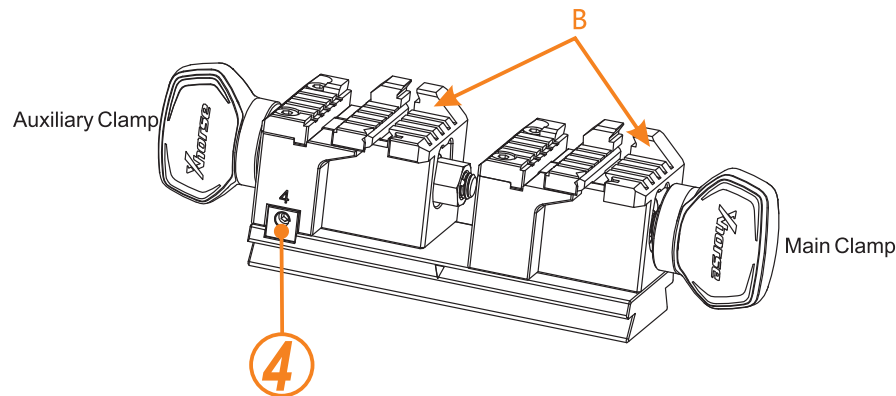

*Notes:

Ensure more accuracy, use two same size probes with high priority. Don't recommend that you use two same size cutters. Never use different size probe or cutter to do calibration.

5.5 Probe/cutter height adjustment

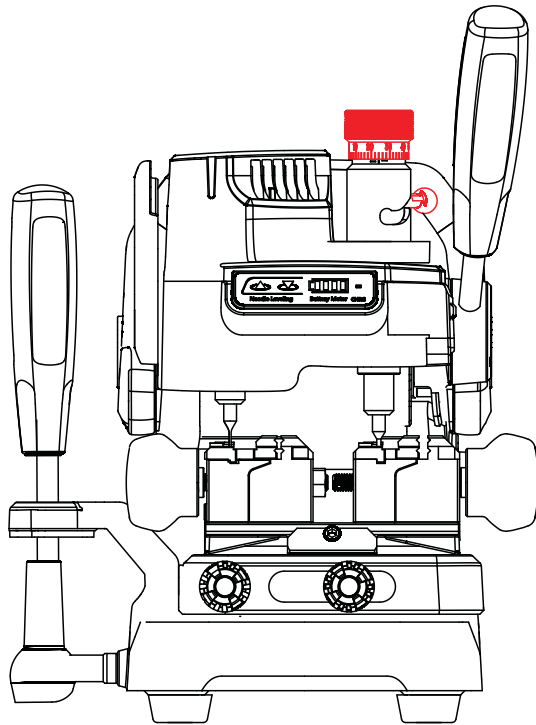

- 1) Turn the prepositioning switch to the 'up' position and install the cutter and probe. Move down the probe and cutter by pulling the main handle.
- 2) If the cutter touch the clamp first, the indicative light on the cutter side will be on. Move the micro-adjuster knob clockwise until the indicative light on the probe side is on also.
- 3) If the probe touch to the clamp first, the indicative light on the probe side will be on. Move the micro-adjuster knob counter-clockwise until the indicative light on the cutter side is on also.

5.6 Fuse replacement and installation

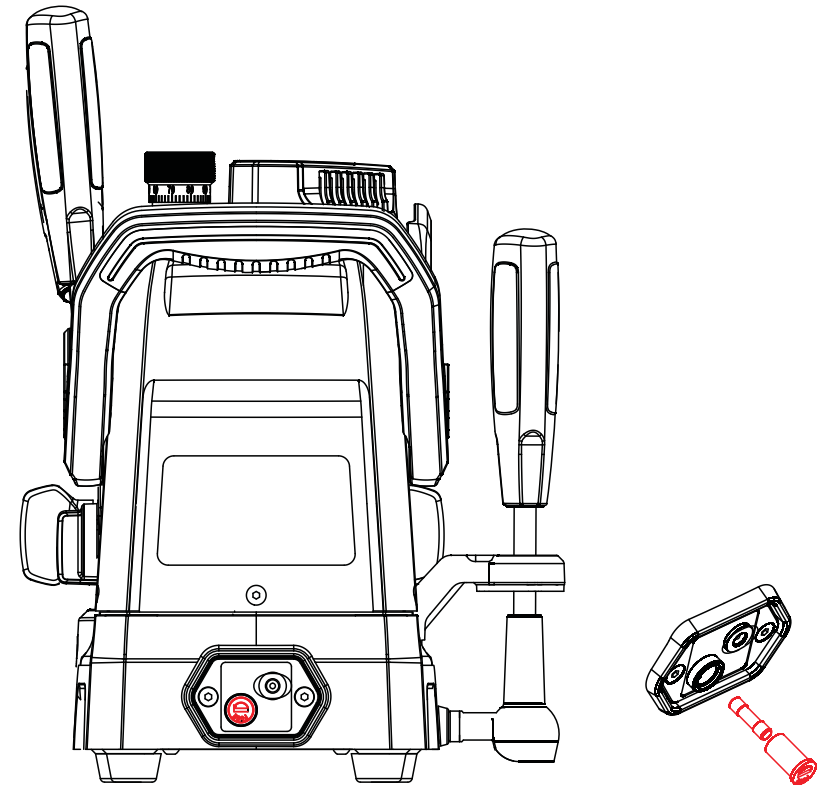

- 1) Change fuse: push the slotted screwdriver and turn it 90° counter-clockwise for remove the fuse box.
- 2) Fuse installation: After the fuse is changed, turn it 90° clockwise and tighten the fuse box back.

***Notes:**

Please switch off and unplug the machine during the change of fuse and when the machine is not used for a long time.

6. Operation guide

6.1 Key alignment

The alignment of keys includes shoulder alignment and tip alignment:

1) Shoulder alignment is shown in the pictures below.

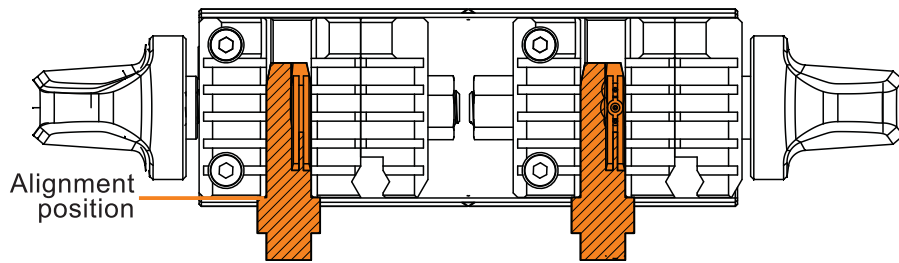

2) Tip alignment is shown in the pictures below. The align stopper is used to fix key based on the type of key.

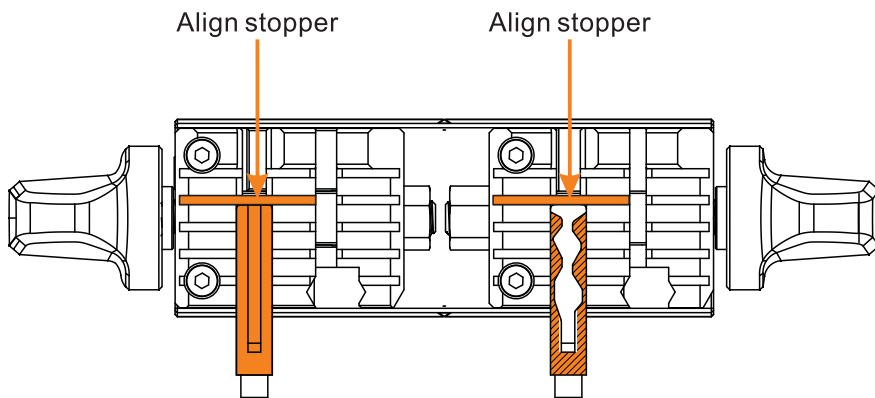

6.2 Key installation guide

6.2.1 Sided keys installation

Sided keys installation shown as picture, need ensure shim. According to the key characteristics, please select proper key align.

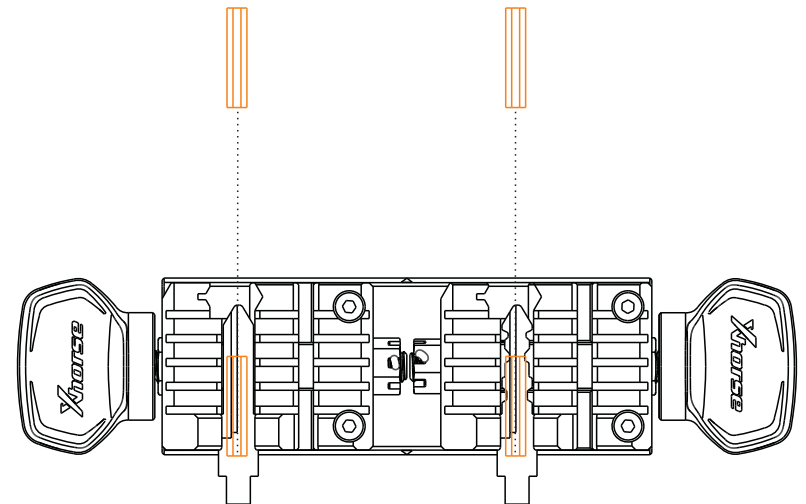
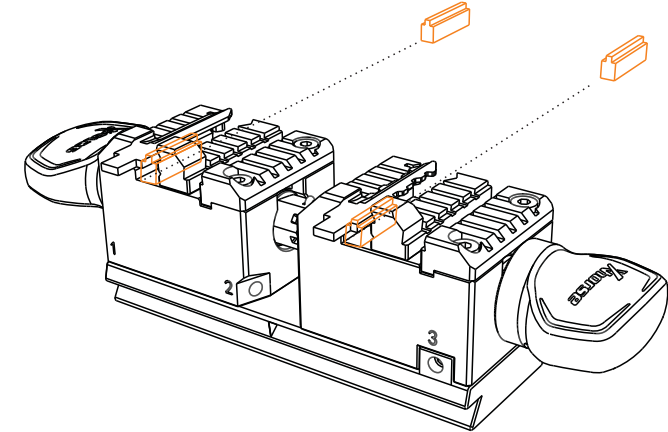

*Notes:

This manual just shown parts of key fixation pictures as sample. This clamp with multi-functional, if any problem for fixing some special keys, please contact technical support.

6.2.2 External keys and internal keys fixation

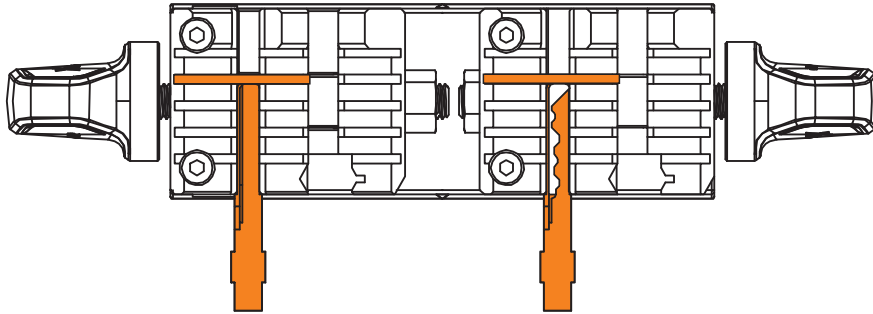

External keys fixation

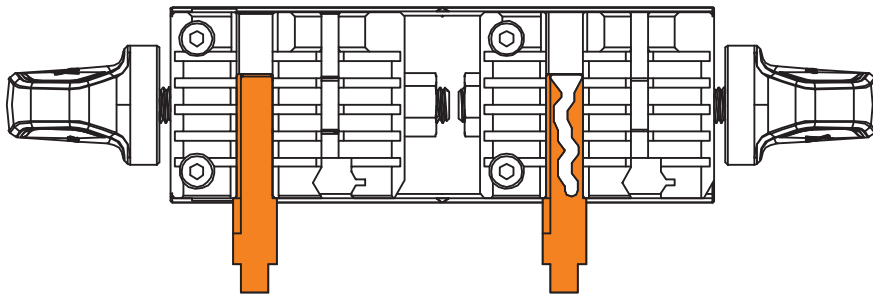

Internal keys fixation

6.2.2 Arc-types keys fixation

For arc-types keys fixation, ensure the base of key blank full attached with clamp then tighten. According to key characteristics to select align position.

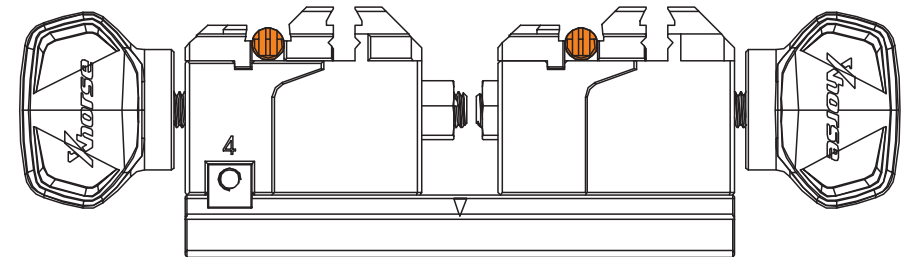
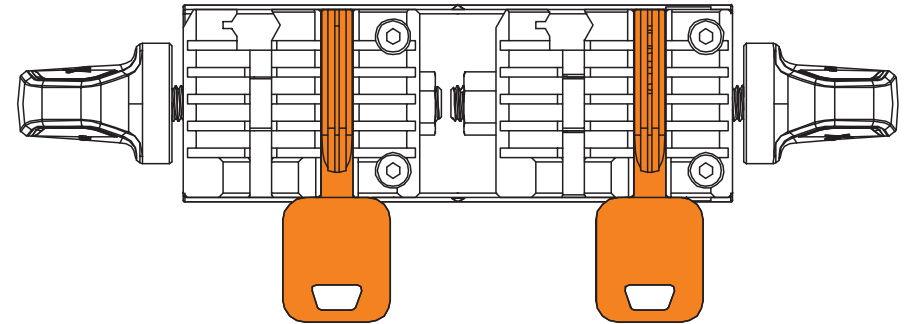

6.2.4 Tubular keys fixation

For tubular keys fixation, need to do height leveling and circular positioning, probe and cutter can use for height leveling tool. Clamp V type groove and the key characteristics can use for circular positioning, shown as follow pictures.

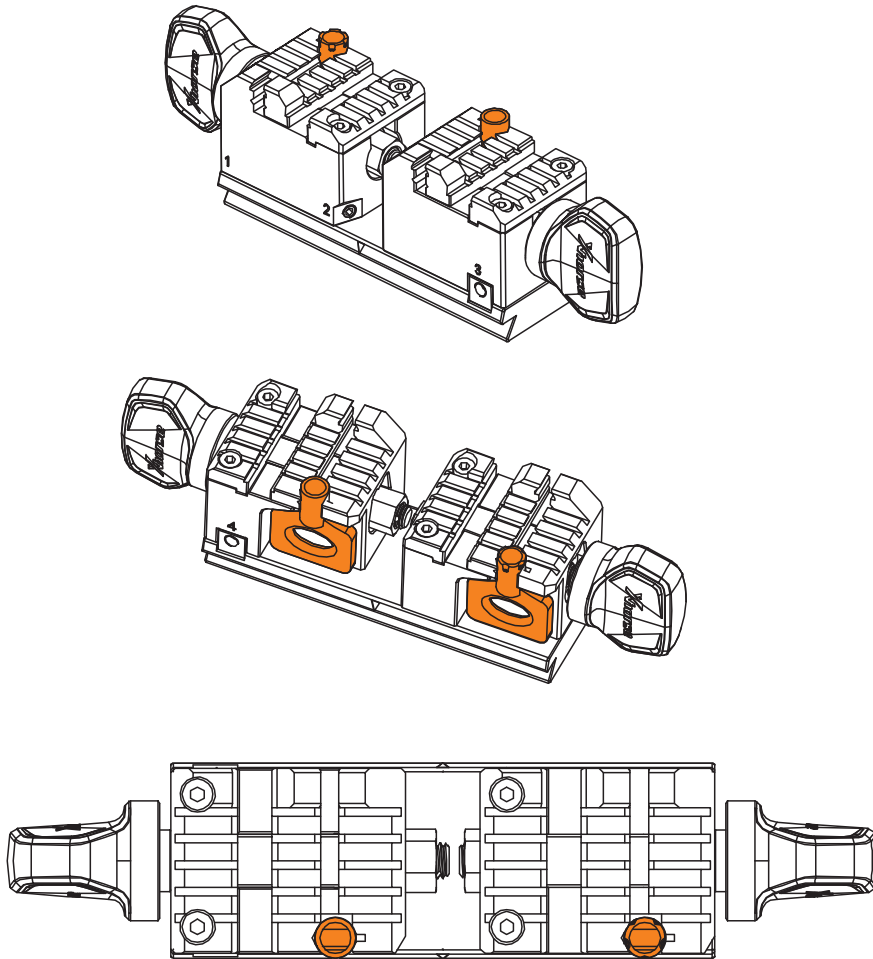

7. Maintenance

- Please clean the area around clamps with a brush before the machine starts to work. This is to assure cutting precision and avoid components damage by metal particles.
- To avoid damage or corrosion to the machine, please do not use cleaning products to clean the machine.
- Please do not flush or wet the machine with water, in case rust and electrical current leakage.
- Under any circumstance, please do not try to clean the working area with air guns and drying machines, in case any metal carvings getting inside the machine.

8. Warranty and after-sale description

DOLPHIN XP-007 has a warranty of 1 year for machine and six months for battery. The warranty starts from the date on invoice. If there is no invoice or the invoice is missing, purchase records from factory is used as reference.

Within Warranty, free maintenance and repairing is not provided if the machine becomes dysfunctional due to the following reasons:

- Operation without referring to or violating the user manual
- Modifications or repairs to the machine by individuals
- Falling, knocking or wrong voltage
- Force majeure
- Use of the machine in places such as ships that are bad for the machine for a long time
- Damaged or worn-out plastic case and protective shield due to frequent use

Regarding to customer service and technical support, please contact distributors or Xhorse online customer service team by scanning the QR code below and downloading Xhorse official App.



Xhorse APP

All the information and illustrations in this document are for guidance only. Xhorse reserves the right to alter products designs, dimensions or info to improve the products quality. The contents of this document are fully protected by Copyright and may not be copied or reproduced in any form (e.g. mechanical, electronic, printing or video recording), without permission from Xhorse.